

MALE END VIEW

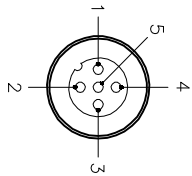

- 1 = BROWN
- 2 = WHITE
- 3 = BLUE
- 4 = BLACK
- 5 = DRAIN

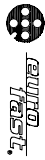

SPECIFICATIONS

CONTACT CARRIER MATERIAL	NYLON OR TPU
MOULDED HEAD MATERIAL/COLOR	TPU/BLACK
CONTACT MATERIAL/PLATING	BRASS/GOLD
HOUSING, LOCKNUT MATERIAL/FINISH	STAINLESS STEEL/PASSIVATED
RATED CURRENT [A]	4.0 A
RATED VOLTAGE [V]	250 V
OUTER CABLE JACKET MATERIAL/COLOR	PVC/BLUE
CONDUCTOR INSULATION MATERIAL	PVC/NYLON (NYLON OVERCOAT)
NUMBER OF CONDUCTORS [AWG]	4x18 AWG
DRAIN/SHIELD	20 AWG/ALUM.-POLYESTER FOIL
TEMPERATURE RANGE	-40°C to +105°C (-40°F to +221°F)
PROTECTION CLASS	NEMA 1,3,4,6P AND IEC IP68, IP69K
CABLE RATING	UL: ITC-ER, DIRECT BURIAL/PLTC-ER/AWM, 105C, 300V CSA: CIC/AWM, 105C, 300V

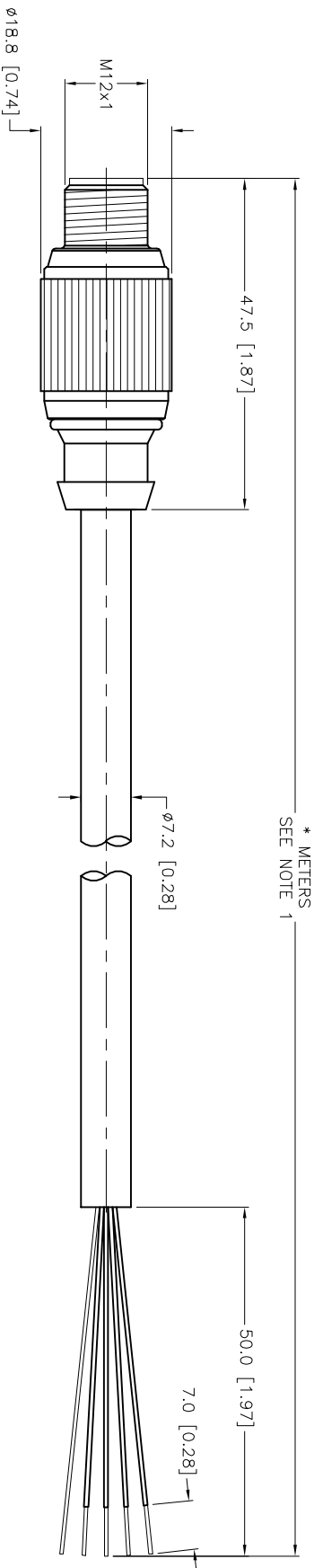

CABLE LENGTH	TOLERANCE *
ALL LENGTHS	+ 4% (OR 50mm) OF LENGTH - 0% (OR 0mm) OF LENGTH WHICHEVER IS GREATER
STRIP LENGTH	TOLERANCE *
0-7mm	±0.5mm
8-29mm	±1.0mm
30-49mm	±2.0mm
50-69mm	±3.0mm
70-100mm	±4.0mm
OVER 100mm	±5.0mm

\* UNLESS OTHERWISE SPECIFIED

NOTES:

1. "\*" INDICATES CABLE LENGTH IN METERS. CONTACT TURCK TO ORDER SPECIFIC LENGTHS.
2. 2020 NEC NOW REQUIRES A DEDICATED GROUND CONDUCTOR FOR ITC-ER AND PLTC-ER CABLES WHEN INSTALLED IN HAZARDOUS LOCATIONS. ALTHOUGH UL CABLE STANDARDS DO NOT REQUIRE A GROUND CONDUCTOR, THIS PRODUCT DOES NOT HAVE A DEDICATED GROUND CONDUCTOR. THEREFORE, WHEN INSTALLED IN A HAZARDOUS LOCATION, THE INSTALLATION PRACTICES FOR ITC OR PLTC CABLES MUST BE FOLLOWED TO PROVIDE GROUND CONTINUITY.

SOURCE DRAWING - FOR REFERENCE ONLY

D	ADDED 2020 NEC NOTE	ER	11/13/20	5000000001912
REV	DESCRIPTION	BY	DATE	ECO NO.

RELATED DOCUMENTS	1. 2. 3. 4.	3RD ANGLE PROJECTION	THIS DRAWING IS CONFIDENTIAL AND THE PROPERTY OF TURCK INC. USE OF THIS DOCUMENT WITHOUT WRITTEN PERMISSION IS PROHIBITED.	DATE 05/21/12	DESCRIPTION P-RSGV 5,33T-1727-*
MATERIAL	SEE SPECIFICATIONS	ALL DIMENSIONS DISPLAYED ON THIS DRAWING ARE FOR REFERENCE ONLY	DRFT KMY	SCALE 1=1.0	IDENTIFICATION NO.
FINISH	SEE SPECIFICATIONS	CONTACT TURCK FOR MORE INFORMATION	APVD C.K.	UNIT OF MEASUREMENT MILLIMETER [ INCH ]	REV
SEE SPECIFICATIONS			DO NOT SCALE THIS DRAWING		D
					FILE: 777029170
					SHEET 1 OF 1



3000 CAMPUS DRIVE  
MINNEAPOLIS, MN 55441  
1-800-544-7769  
(763) 553-7300  
(763) 553-0708 fax  
www.turck.us